

**ATON** Technology in reach.™

# Storm Series

## Indoor/Outdoor Speakers

041/051/061/062/062ST



**ATON**  
**STORM**  
SERIES



[www.atonhome.com](http://www.atonhome.com)



## 1. Introduction

Thank you for choosing ATON Storm Series Outdoor Speakers. All models were voiced in our sound labs by musicians with years of critical listening experience and crafted for your listening enjoyment. To see the complete line of ATON products, visit us online at [www.atonhome.com](http://www.atonhome.com).

**Storm Series** Outdoor Speakers are designed to extend the listening experience into areas not traditionally associated with high quality sound: the Great Outdoors! The **041/051/061** line provides high quality sound at affordable prices for traditional stereo or mono listening areas. Injection-Molded Graphite (IMG) woofers and 1" Treated Soft-Dome Tweeters provide deep, rich bass and smooth highs for an authentic, exciting listening experience. The **062** and **062ST** models use Woven Fiberglass Woofers and 1" Aluminum Tweeters for even better sound quality that will last for years in any weather conditions. The 062 is designed for typical stereo and mono applications while the 062ST is a Dual-Voice Coil (DVC) design that allows stereo signals to play from a single speaker!

**Storm Series** Outdoor Speakers are also ideal for use *indoors*, too! Use them as primary stereo speakers in any system, or connect them as rear surround speakers in Home Theater systems. The 062ST can also be used in areas such as hallways, laundry rooms and kitchens to provide full stereo sound in unexpected places.

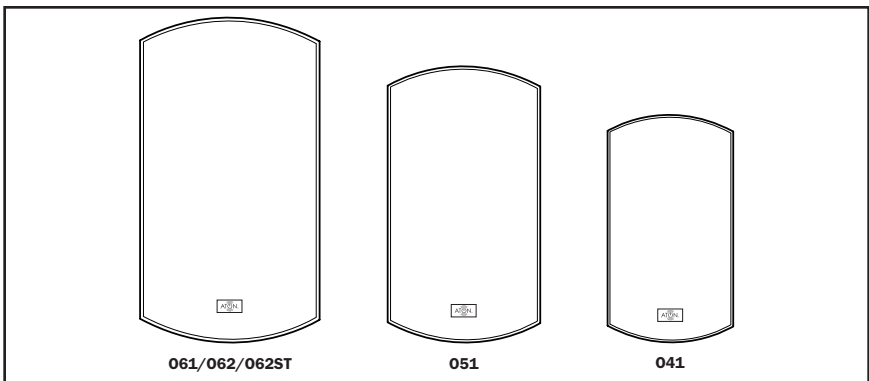

Figure 1.1 - Front View

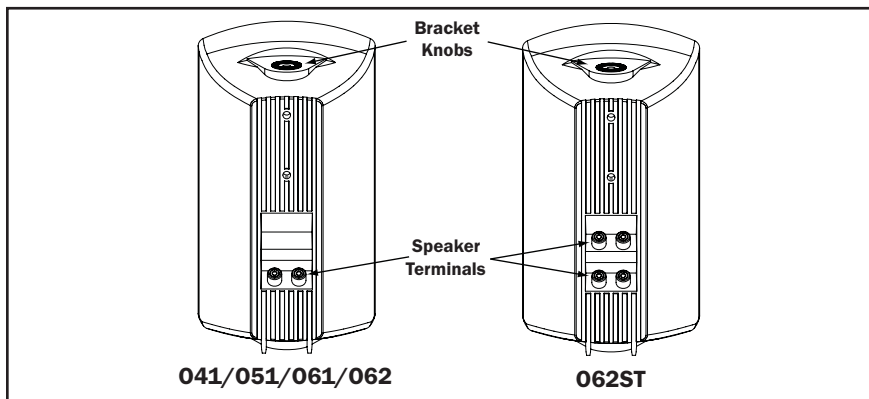

Figure 1.2 - Rear View

## 2. System Design/Applications

ATON Outdoor speakers are designed primarily to be used in areas such as back yards, porches, decks, etc. Because of the diversity of possible installation scenarios, pay particular attention to which type of application is most appropriate for the environment in which the speakers will be installed.

### Stereo

In areas that have a defined listening area where two speakers will be mounted more or less equidistant from each other, use a stereo setup with left and right speakers each connected to their own channel of a stereo receiver or amplifier. This application provides the best sound quality, staging, and depth possible in areas with a defined listening position. **Figure 2.1** shows an example of an outdoor stereo listening area.

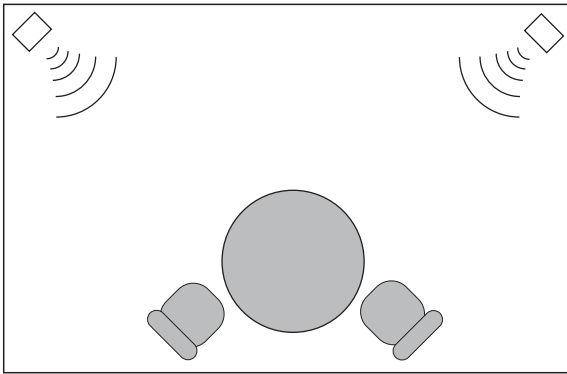

**Figure 2.1 - Stereo Application**

### Mono/DVC

In many instances, mono or DVC setup will provide a better listening experience in outdoor areas. Mono applications combine the left and right signals to provide the full sound of a piece of music to each speaker in the system without left/right separation. DVC applications send the left signal to one voice coil and the right signals to another voice coil, essentially creating a stereo pair in one speaker cabinet. Use mono or DVC setups for any area that does not have a defined listening area.

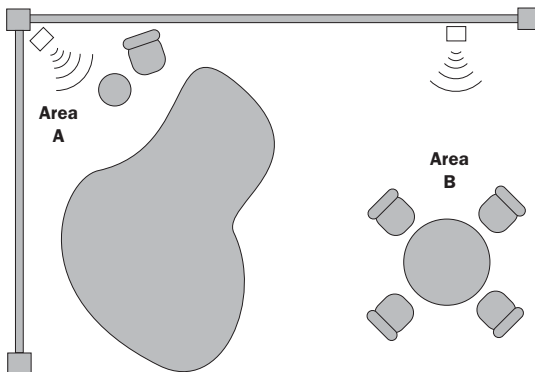

**Figure 2.2 - Mono/DVC Application**

## 3. Installation

The Installation process is divided into three distinct processes: **Wiring, Mounting,** and **Connection.** After carefully considering the intended application (defining a Listening Area, Mono/Stereo, etc.) specific mounting locations can be decided upon. Once the specific locations are determined, installation can commence.

### Wiring

Before actually running any wire or cable, take the time to look around each room or area of the house and plan your wire paths for maximum efficiency. Look for routes through uncluttered parts of the stud wall or ceiling that allow you to group all low-voltage wires wherever possible. It is a good practice to label both ends of all cables and to protect wires by tying a plastic bag over the ends.

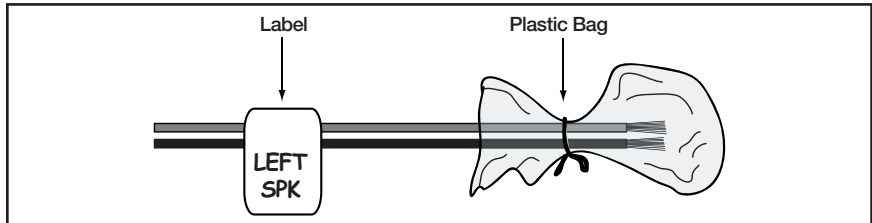

Figure 3.1 - Wiring Label & Plastic Bag

### Wiring Methodology

There are three common scenarios for connecting speakers to an audio system. **Figures 3.2 to 3.4** show stereo pairs, while **Figures 3.5** and **3.6** show examples of mono and DVC applications, respectively. **Each stereo method can also be used for mono or DVC applications.**

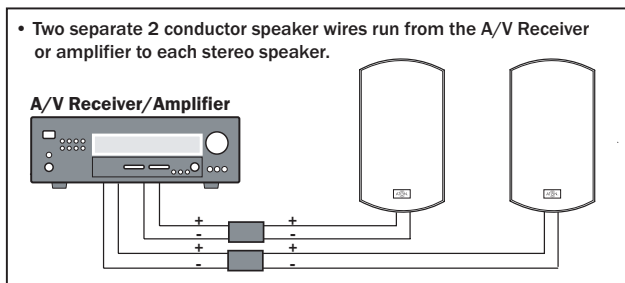

Figure 3.2 - Wiring: Amplifier to Speakers-2 Conductor Direct

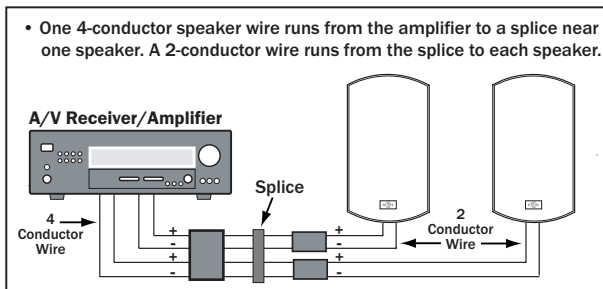
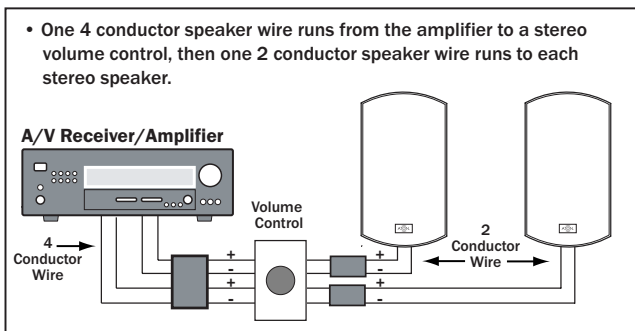
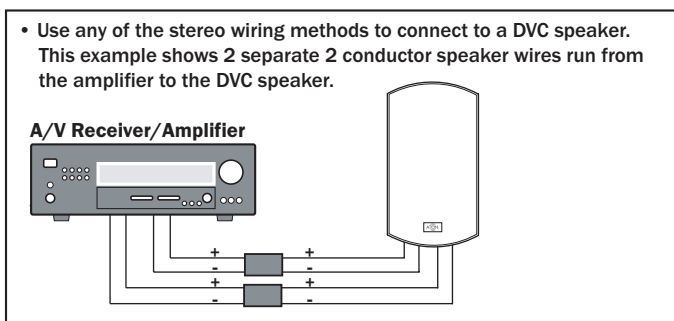

Figure 3.3 - Wiring: Amplifier to Speakers-4 Conductor to 2 Conductor



**Figure 3.4 - Wiring: Amplifier to Speakers w/ Volume Control**



**Figure 3.5 - Wiring: Amplifier to Speaker-DVC**

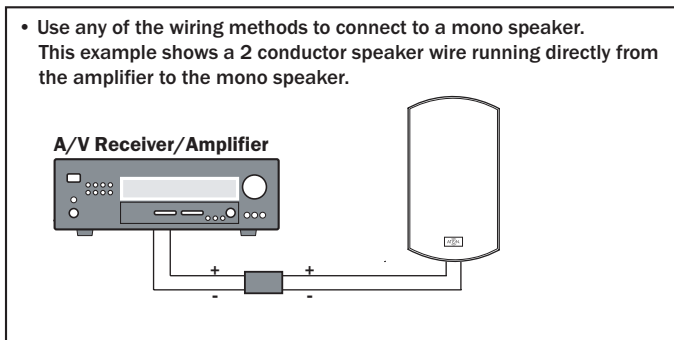

**Figure 3.6 - Wiring: Amplifier to Speaker-Mono**

**Note 1:** Low voltage wiring must be run in accordance with the National Electrical Code as well as any other applicable provisions of the local building codes in your area. In some cases (such as commercial installations), running the wire in conduit may be required. If you have any questions concerning the wiring of speakers in your home, contact your local building and inspection department.

**Note 2:** It is recommended that you use quality CL-2 or CL-3 rated stranded speaker wire when installing ATON speakers. Solid-core "Romex" type wire is not acceptable! Use at least 16AWG speaker wire for runs up to 100 feet, and at least 14 AWG speaker wire for runs up to 200 feet. If you must cross high-voltage lines, always do so at a 90 degree angle to avoid audible hum through the speakers!

**Note 3:** When pre-wiring for outdoor speakers, it is essential to make direct wire runs from the head-end to each speaker. Do not run speaker wires in series or parallel, and do not "daisy-chain" speakers to common wiring. There are instances where speakers will be connected directly to an amplifier. The use of spade lugs or banana plugs is recommended in these instances.

## Mounting

Use the included Mounting Brackets to securely mount the speakers in the desired location.

### To install the brackets on wood surfaces, vinyl siding, etc.:

1. Place brackets in desired location.
2. Mark location of holes at the narrow point of the keyhole cutout.
3. Drill pilot holes..
4. Partially tighten screws.
5. Place the brackets in position, then tighten the screws.

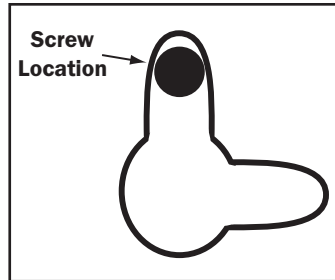

Figure 3.7 - Screw Location

### To install the brackets on brick or concrete surfaces:

1. Place brackets in desired location
2. Mark location of holes at the narrow point of the keyhole cutout
3. Drill holes using a masonry drill bit.
4. Insert masonry anchors into the holes previously drilled
5. Tighten screws partway into the anchors
6. Mount the brackets then tighten screws

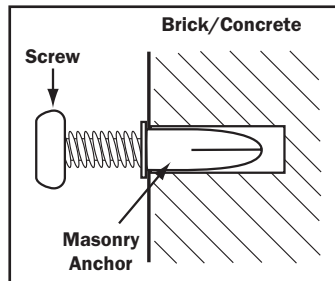

Figure 3.8 - Brick/Concrete

### To install the brackets on drywall:

1. Place brackets in desired location
2. Mark location of holes at the narrow point of the keyhole cutout
3. Drill holes using a drill bit.
4. Insert drywall anchors into the holes previously drilled
5. Tighten screws partway into the anchors
6. Mount the brackets then tighten screws

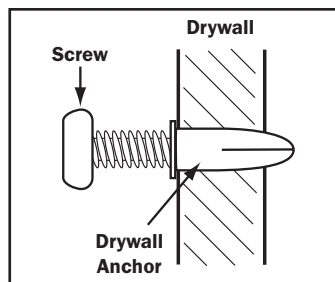
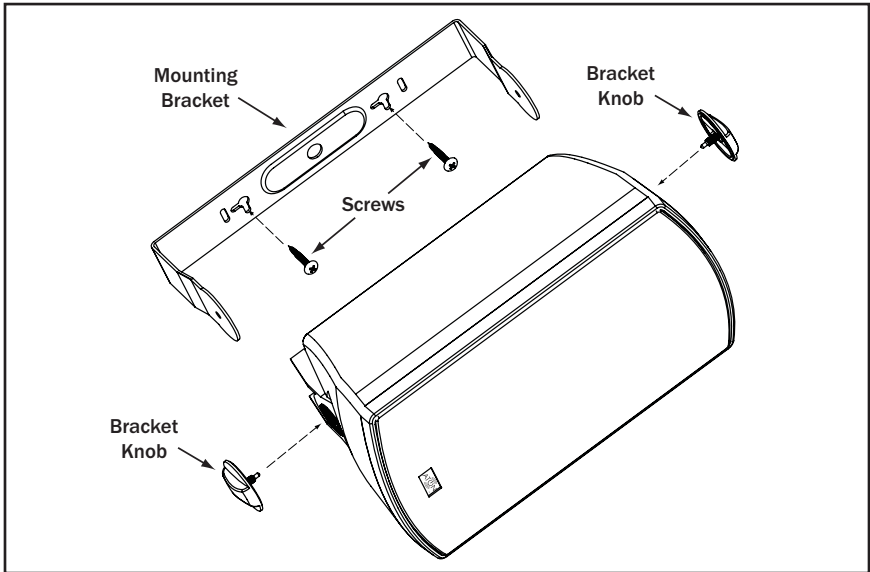

Figure 3.9 - Drywall

Once the brackets are mounted, place the speakers between each end of the bracket. Install a Bracket Knob on each end of the speaker as shown in **Figure 3.10**. Adjust the speaker to the desired location, and firmly tighten the Bracket Knob.



**Figure 3.10 - Mounting Speaker to Bracket**

### Connection

Once the speakers are mounted, they can be connected to the wires previously installed. Cut the ends of the wire to length, allowing some free play (about 6 inches of slack) to allow for moving the speakers and physically connecting them to the wire. Using wire strippers, remove 1/2 inch of insulation, then twist the wire to ensure that no stray strands are evident. Define positive (+) and negative (-) at the amplifier end and the speaker end of the wire run and use the same conductor on each end.

### Several Connection methods are possible:

1. **Bare wire** - Loosen the binding post of the speaker and insert bare wires into the holes on the side of the connector; + to + (red) and - to - (black). Tighten the binding post to make sure the wires are firmly connected.
2. **Bannana Plugs** - Terminate the speaker wires with Bannana plugs, loosen the binding posts, then insert the plugs into the center holes; + to + (red) and - to - (black). Tighten the binding posts to ensure a snug fit.
3. **Spade Lugs** - Terminate the speaker wires with Spade Lugs, loosen the binding posts, then position the spade lugs behind the binding post; + to + (red) and - to - (black). Tighten the binding posts to ensure a snug fit.



## 4. Specifications

### 041

System Type.....	2-Way
Woofers.....	4.25" Injection Molding Graphite (IMG)
Tweeter .....	1" (25mm) Treated Soft Dome
Connectors .....	5-Way Binding Posts
Crossover .....	Second Order customized "Q"
Nominal Impedance .....	8 Ohms
Sensitivity .....	87dB
Frequency Response.....	55Hz to 20kHz
Power Handling .....	100 Watts
Dimensions (without bracket).....	5-3/4"(W) x 9-5/8"(H) x 6-1/8"(D)
	147mm(W) x 245mm(H) x 156mm(D)

### 051

System Type.....	2-Way
Woofers.....	5.25" Injection Molding Graphite (IMG)
Tweeter .....	1" (25mm) Treated Soft Dome
Connectors .....	5-Way Binding Posts
Crossover .....	Second Order customized "Q"
Nominal Impedance .....	8 Ohms
Sensitivity .....	88dB
Frequency Response.....	45Hz to 20kHz
Power Handling .....	125 Watts
Dimensions (without bracket).....	6-1/2"(W) x 10-13/16"(H) x 6-3/4"(D)
	165mm(W) x 275mm(H) x 172mm(D)

### 061

System Type.....	2-Way
Woofers.....	6.5" Injection Molding Graphite (IMG)
Tweeter .....	1" (25mm) Treated Soft Dome
Connectors .....	5-Way Binding Posts
Crossover .....	Second Order customized "Q"
Nominal Impedance .....	8 Ohms
Sensitivity .....	89dB
Frequency Response.....	38Hz to 20kHz
Power Handling .....	150 Watts
Dimensions (without bracket).....	7-5/16"(W) x 13-5/16"(H) x 7-5/16"(D)
	186mm(W) x 338mm(H) x 186mm(D)

### 062

System Type.....	2-Way
Woofers.....	6.5" Woven Fiberglass
Tweeter .....	1" (25mm) Aluminum
Connectors .....	5-Way Binding Posts
Crossover .....	Second Order customized "Q"
Nominal Impedance .....	8 Ohms
Sensitivity .....	91dB
Frequency Response.....	35Hz to 20kHz
Power Handling .....	175 Watts
Dimensions (without bracket).....	7-5/16"(W) x 13-5/16"(H) x 7-5/16"(D)
	186mm(W) x 338mm(H) x 186mm(D)

### 062ST

System Type.....	Dual Voice Coil (DVC)
Woofers.....	6.5" Woven Fiberglass
Tweeter .....	1" (25mm) Aluminum
Connectors .....	5-Way Binding Posts
Crossover .....	Second Order customized "Q"
Nominal Impedance .....	6 Ohms
Sensitivity .....	88dB
Frequency Response.....	35Hz to 20kHz +/-3dB
Power Handling .....	175 Watts RMS
Dimensions.....	7-5/16"(W) x 13-5/16"(H) x 7-5/16"(D)
	186mm(W) x 338mm(H) x 186mm(D)



**Notes:**



## Limited Warranty

ATON\* warrants to the purchaser/end user (“you”) that Storm Series Outdoor Speakers are to be free from defects in materials and workmanship for a period of ten (10) years from date of purchase (the “Warranty Period”). This warranty is transferable to subsequent owners of the product as long as the original proof of purchase is retained. If you discover a defect in material or workmanship within the Warranty Period, you can obtain warranty service by contacting ATON during the Warranty Period at (859)-422-7137 or [service@atonhome.com](mailto:service@atonhome.com). If ATON determines that the product is in fact defective, ATON shall, at its option, repair or replace the product free of charge to you.

This warranty shall not apply to equipment (a) not manufactured by ATON, (b) to equipment which was improperly installed, (c) which was repaired or altered by persons other than ATON or its authorized representatives or subject to unauthorized tampering, alteration or modification, (d) damaged due to misuse, negligence, accident, acts of God (including, but not limited to, excess moisture, insects, lightning, flood, electrical surge, tornado, earthquake, or other catastrophic events beyond ATON’s control), or (e) subject to improper operation, maintenance or storage or unreasonable use. The foregoing warranties do not cover reimbursement for labor, transportation, removal, installation or other expenses which may be incurred in connection with repair or replacement. The foregoing remedies shall be your exclusive remedies for any breach of warranty.

Further, the foregoing warranty does not extend to equipment sold, but not manufactured by, ATON (“Third Party Products”). With respect to any Third Party Products, the warranty for such product shall be as provided by the manufacturer of such product, who will also be responsible for warranty service, and ATON will pass through to you any transferable warranty actually extended to ATON by the manufacturer.

THE FOREGOING WARRANTIES ARE EXCLUSIVE AND IN LIEU OF ALL OTHER EXPRESSED AND IMPLIED WARRANTIES. ATON EXPRESSLY DISCLAIMS ALL SUCH OTHER WARRANTIES, INCLUDING BUT NOT LIMITED TO IMPLIED WARRANTIES OF MERCHANTABILITY, FITNESS FOR A PARTICULAR PURPOSE AND NON-INFRINGEMENT. Notwithstanding the above, where applicable, if you qualify as a “consumer” under the Magnuson-Moss Warranty Act, then you may be entitled to any implied warranties allowed by law for the Warranty Period. Some states do not allow limitations on how long an implied Limited Warranty lasts, so the above limitation may not apply to you.

### ATTENTION: TO OUR VALUED CONSUMERS

Valid proof of purchase is required for all warranty services. Warranty service requests made without proof of date of purchase will be denied. Please keep the original sales receipt for your records and send a copy to request warranty service. This warranty gives you specific legal rights, and you may also have other rights which vary state to state.

\*ATON is a division of ELAN Home Systems, LLC.



[www.atonhome.com](http://www.atonhome.com)  
or  
[service@atonhome.com](mailto:service@atonhome.com)